

## Chapter 1: Groups, intuitively

Matthew Macauley

Department of Mathematical Sciences  
Clemson University

<http://www.math.clemson.edu/~macaule/>

Math 4120/4130, Visual Algebra

# The science of patterns

G.H. Hardy (1877–1947) famously said that “*Mathematics is the Science of Patterns.*”

He was also the PhD advisor to the brilliant Srinivasa Ramanujan (1887–1920), the central character in the 2015 film *The Man Who Knew Infinity*.

In his 1940 book *A Mathematician's Apology*, Hardy writes:

*“A mathematician, like a painter or a poet, is a maker of patterns. If his patterns are more permanent than theirs, it is because they are made with ideas.”*

Another theme is that the inherent beauty of mathematics is not unlike elegance found in other forms of art.

*“The mathematician's patterns, like the painter's or the poet's must be beautiful; the ideas like the colours or the words, must fit together in a harmonious way.”*

Very few mathematical fields embody visual patterns as well as [group theory](#).

We'll motivate the idea of a group by starting with the symmetries of a rectangle.



## Our first group

The four symmetries of a rectangle can be visualized using a **Cayley graph**, named after British mathematician Arthur Cayley (1821–1895).

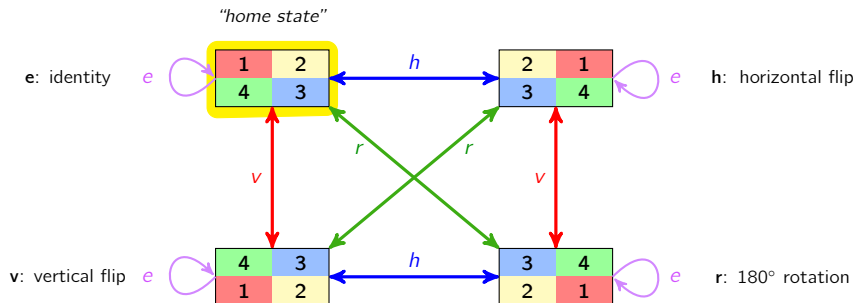

The set  $\text{Rect} = \{e, h, v, r\}$  of four **symmetries** is our first example of a **group**.

*Observations?*

## Groups, informally

A **group** is a **set of actions**, satisfying a few mild properties.

### Basic properties

- **Closure**: Composing actions in any order is another action.
- **Identity**: There is an **identity action**  $e$ , satisfying

$$ae = a = ea$$

for all actions  $a$ . [*Often we use 1 instead of  $e$ .*]

- **Inverses**: Every action  $a$  has an **inverse action**  $b$ , satisfying

$$ab = e = ba.$$

We call the operation of composing actions **multiplication**, and write it from **left-to-right**.

Every group has a **generating set**, and we use angle brackets to denote this.

We usually prefer to find a **minimal generating set**. For example,

$$\mathbf{Rect} = \langle v, h \rangle = \langle v, r \rangle = \langle h, r \rangle = \langle v, h, r \rangle = \langle v, h, e \rangle = \dots$$

There still something missing from the above definition of a group. (Stay tuned!)

# Minimal generating sets

Different minimal generating sets might lead to different Cayley graphs:

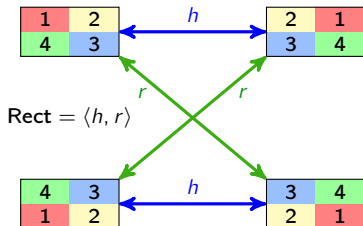
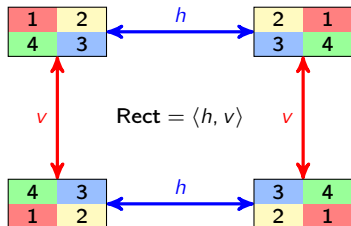

## Remarks

The group  $\mathbf{Rect}$  has some properties that are not always true for other groups:

- it is **abelian**:  $ab = ba$  for all  $a, b \in \mathbf{Rect}$
- every element is its own inverse:  $a^{-1} = a$  for all  $a \in \mathbf{Rect}$
- the Cayley graphs for any two minimal generating sets have the same structure
- all minimal generating sets have the same size.

## Symmetries of a triangle

Consider the group of symmetries of a triangle.

This group is **nonabelian** – order matters!

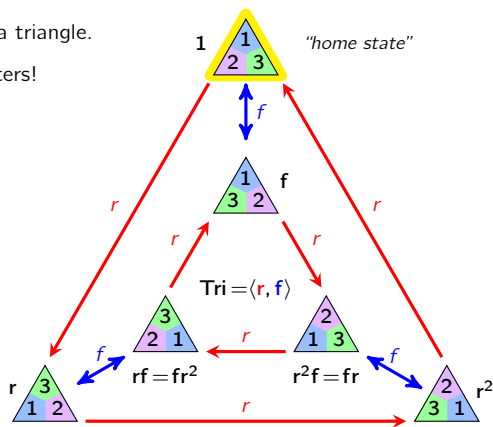
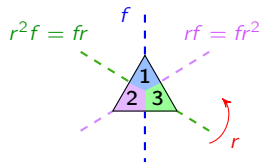

Equivalences of actions like the following are called **relations**:

$$r^3 = 1, \quad f^2 = 1, \quad rf = fr^2, \quad fr = r^2 f.$$

The Cayley graph makes it easy to find the **inverse** of each action:

$$1^{-1} = 1, \quad r^{-1} = r^2, \quad (r^2)^{-1} = r, \quad f^{-1} = f, \quad (rf)^{-1} = rf, \quad (r^2 f)^{-1} = r^2 f.$$

## Cayley graph structure

Any action with  $a^2 = 1$  is its own inverse:  $a^{-1} = a$ .

When this happens, we will use **undirected arrows** instead of bi-directed or double arrows:



Four of the six actions in  $\mathbf{Tri} = \langle r, f \rangle$  are their own inverse.

Cayley graphs must have a certain **regularity**: if  $rf = fr^2$  holds from one node, it must hold from every node.

*Do either of the following graphs have this regularity property?*

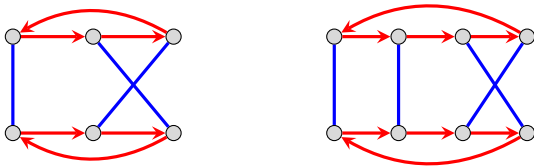

## A different generating set for the triangle symmetry group

Recall the triangle symmetry group

$$\mathbf{Tri} = \underbrace{\{1, r, r^2\}}_{\text{rotations}}, \underbrace{\{f, rf, r^2f\}}_{\text{reflections}}.$$

Notice that the composition of two reflections is a 120° rotation:

$$(rf) \cdot f = rf^2 = r \cdot 1 = r, \quad f \cdot rf = f \cdot fr^2 = 1 \cdot r^2 = r^2.$$

Let's see a Cayley graph corresponding to  $\mathbf{Tri} = \langle s, t \rangle$ , where  $s := f$  and  $t := r^2f = fr$ .

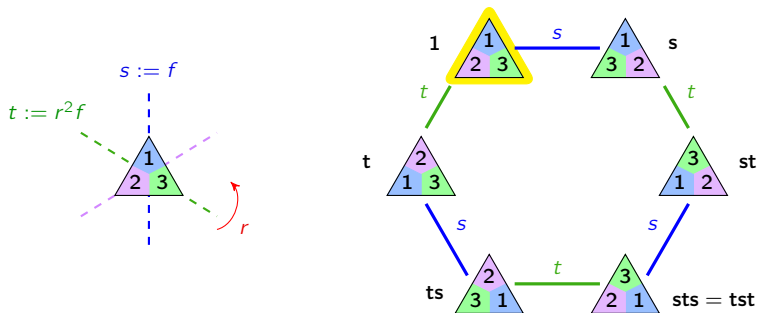



## Minimal vs. minimum generating sets

There is a subtle but important difference between **minimal** and **minimum**.

For example, consider the group of symmetries of a hexagon:

$$\text{Hex} = \underbrace{\{1, r, r^2, r^3, r^4, r^5\}}_{\text{rotations}}, \underbrace{\{f, rf, r^2f, r^3f, r^4f, r^5f\}}_{\text{reflections}}.$$

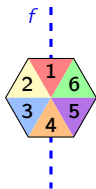

$\langle r, f \rangle$  is a **minimum** (and hence minimal) generating set

$\langle r^2, r^3, f \rangle$  is a **minimal** (but not minimum) generating set

A generating set  $S$  is:

- **minimal** if removing any element makes it no longer generate.
- **minimum** if it is minimal and  $|S| \leq |T|$  for all other generating sets.

For any generating set  $S$  of  $G$ ,

**minimum**  $\Rightarrow$  **minimal**, but **minimal**  $\not\Rightarrow$  **minimum**.

## Groups arising from non-symmetry actions

Consider two light switches in the “down” position. Call this our “home state”.

Let  $\mathbf{Light}_2 = \langle L, R \rangle$  be the group, where

- $L$ : flip left switch
- $R$ : flip right switch

Here is a Cayley graph:

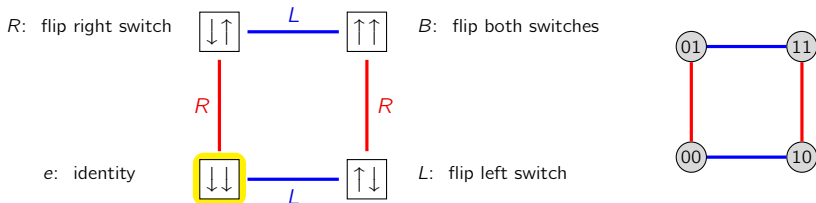

### Remark

The Cayley graphs for  $\mathbf{Rect} = \{e, v, h, r\}$  and  $\mathbf{Light}_2 = \{e, L, R, B\}$  have the same structure. We say they are **isomorphic**, and write

$$\mathbf{Rect} \cong \mathbf{Light}_2 .$$

## Isomorphic groups

The formal definition of two groups being isomorphic is technical, and involves a **structure preserving bijection** between them.

If two groups have generating sets that define Cayley graphs of the same structure, they are isomorphic, and we have a “**Yes Certificate**”.

If the Cayley graphs are different, then the groups are not necessarily non-isomorphic, as we saw with  $\mathbf{Tri} = \langle r, f \rangle = \langle r, f, rf \rangle = \langle f, rf \rangle$ .

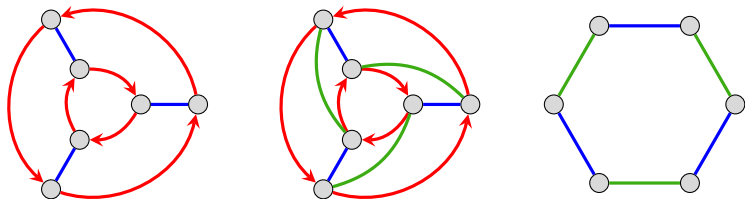

In other words, a “**No Certificate**” is harder to verify.

### Remark

To prove two groups are non-isomorphic, find a property that one has but the other doesn't.

## The three light switch group

The “2 light switch group” generalizes to the “3 light switch group” in the obvious manner:

$$\mathbf{Light}_3 := \langle L, M, R \rangle.$$

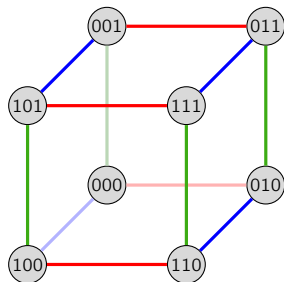
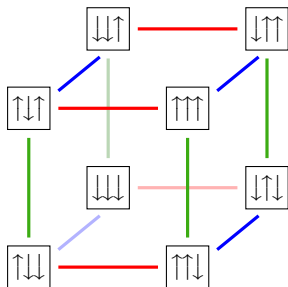

### Properties of $\mathbf{Light}_3$

- this group is **abelian**:  $ab = ba$ , for all  $a, b \in \mathbf{Light}_3$
- every action is its own inverse:  $a^2 = e$ , or  $a^{-1} = a$ , for all  $a \in \mathbf{Light}_3$  (verify!)
- any minimal generating set has size 3 (*not immediately obvious*).

## Another group of size 8

Call the following rectangle configuration our *home state*:



Suppose we are allowed the following operations, or "actions":

- $s$ : swap the two squares
- $t$ : toggle the color of the first square.



Here is a Cayley graph of this group that we'll call  $\text{Coin}_2 = \langle s, t \rangle$ :

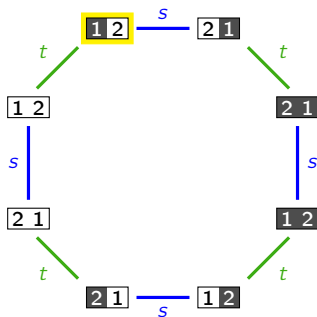

Question: Are the groups  $\text{Coin}_2$  and  $\text{Light}_3$  isomorphic?

## The Rubik's cube group

One of the most famous groups is the set of actions on the **Rubik's Cube**.



### Fact

There are 43,252,003,274,489,856,000 distinct configurations of the Rubik's cube.

This toy was invented in 1974 by architect Ernő Rubik (born 1944) of Budapest, Hungary.

His Wikipedia page used to say:

He is known to be an introvert and hardly accessible person, hard to contact or get for autographs. He typically does not attend [speedcubing](#) events. However, he attended the 2007 World Championship in Budapest.<sup>[2][3]</sup>

# The Rubik's cube group

Not impossible . . . just **almost** impossible.

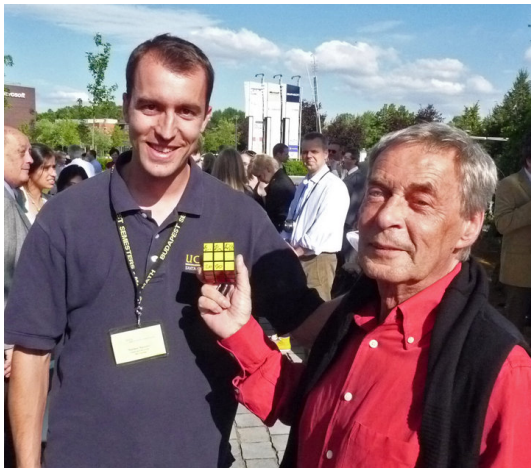

Figure: June 2010, in Budapest, Hungary

## The Rubik's Cube group

The **configurations** of the Rubik's cube are different than the **actions**, but they are in bijective correspondence.

The Rubik's cube group is generated by 6 actions:

$$\text{Rubik} := \langle F, B, R, L, U, D \rangle,$$

where each action is a **90° clockwise turn** of one of the six faces:

- $F$ : front
- $B$ : back
- $R$ : right
- $L$ : left
- $U$ : upper
- $D$ : bottom ("down")

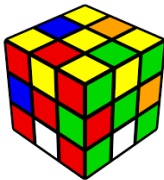

In other words, these six actions generate all  $|\text{Rubik}| = 43,252,003,274,489,856,000$  actions of the Rubik's cube group.

### Theorem (2010)

Every configuration of the Rubik's cube group is at most 20 "moves" from the solved state. Moreover, there are configurations that are exactly 20 moves away.



## The Rubik's Cube group

Though the Rubik's cube group is generated by 6 actions,

$$\mathbf{Rubik} := \langle F, B, R, L, U, D \rangle,$$

most solution guides also use:

- $F', B', R', L', U', D'$  for  $90^\circ$  counterclockwise turns, and
- $F2, B2, R2, L2, U2, D2$  for  $180^\circ$  turns.

The theorem about “*every configuration is at most 20 moves away*” considers this definition for a “*move*.”

The following is a standard definition from graph (or network) theory.

### Definition

The **diameter** of a graph is the longest shortest path between any two nodes.

### Theorem (2010)

The diameter of the Cayley graph of the Rubik's cube group, with generating set

$$\mathbf{Rubik} = \langle F, B, R, L, U, D, F', B', R', L', U', D', F2, B2, R2, L2, U2, D2 \rangle$$

is 20.

## The Rubik's Cube group

In 2014, Tomas Rokicki and Morley Davidson, with the Ohio Supercomputing Center, solved the Rubik's cube in the "*quarter-turn metric*".

### Theorem (2014)

The diameter of the Cayley graph of the Rubik's cube group, with generating set

$$\mathbf{Rubik} = \langle F, B, R, L, U, D, F', B', R', L', U', D' \rangle$$

is 26.

In the "*half-turn metric*," there are **hundreds of millions** of nodes a maximal distance (exactly 20) from the solved state.

In the "*quarter-turn metric*," we only know of **three** at a maximal distance (exactly 26).

It is conjectured that there are

- $\approx 36$  nodes at a distance of 25
- $\approx 150,000$  nodes at a distance of 24
- $\approx 24$  quadrillion ( $2.4 \times 10^{16}$ ) nodes at a distance of 23.

When we study permutation groups, we'll learn why the quarter-turn metric is more natural than the half-turn metric.

## Unlabeled Cayley graphs

Previously, we've labeled the nodes of Cayley graphs with configurations.

If we want to focus on a graph's structure, we can leave the nodes unlabeled.

For example, consider the following two groups of size 4:

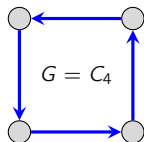
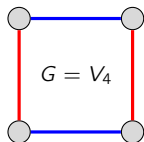

The abstract group isomorphic to **Rect** is the **Klein 4-group**, denoted  $V_4$ , named after German mathematician Felix Klein (1849–1925).



### Questions

- Are the two groups whose Cayley graphs shown above isomorphic?
- Can you think of an object whose symmetry group has the group on the right?

## Cyclic groups (preview)

Groups that can be generated by a single action are called **cyclic**.

These describe shapes that have only rotational symmetry.

The shape of a molecule of boric acid,  $B(OH)_3$ , is shown below. It should be clear that there are three symmetries:

- the identity action,  $1$
- $120^\circ$  counterclockwise rotation,  $r$
- $240^\circ$  counterclockwise rotation,  $r^2$ .

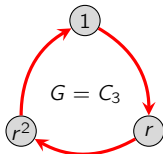
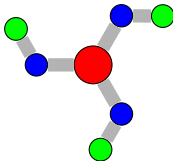

The boric acid molecule is **chiral** because a mirror reflection is not a symmetry.

Inorganic chemists use groups theory to classify molecules by their symmetries.

The triangle symmetry group  $\mathbf{Tri} = \langle r, f \rangle$  contains  $C_3 = \langle r \rangle$  as a subset. We say that  $C_3$  is a **subgroup** of  $\mathbf{Tri}$ .

## Labeling Cayley graphs with actions

When drawing Cayley graphs, we have done one of two things with the nodes:

1. Label nodes with **configurations** of an object.
2. Leaving nodes unlabeled.

There is a 3rd choice, since every **path** represents an **action** in the group.

3. Label the nodes with **actions**.

Here is one way to do this for the **Klein 4-group**,  $G = V_4$ :

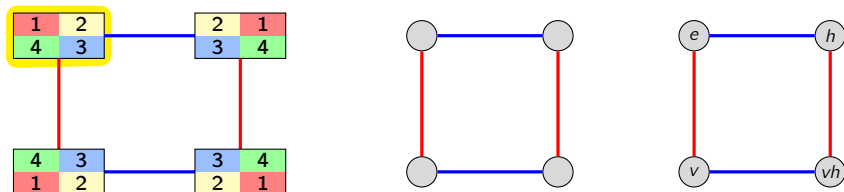

By the “regularity property” of Cayley graphs, it does not matter where we start, or what path we take when labeling.

## Labeling Cayley graphs with actions

Here are two canonical ways to label the nodes of the Cayley graph of  $\mathbf{Tri} = \langle r, f \rangle$ .

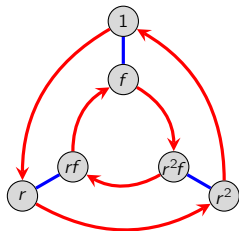
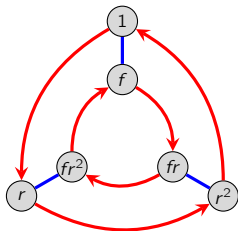
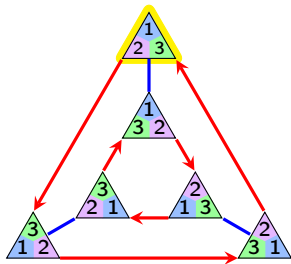

Technically, these are **right Cayley graphs** because we are reading from left-to-right.

In other words, traversing around the graph corresponds to **right multiplication**.

### Remark

Every **path** corresponds to an action  $a \in G$ . To compute a path for  $ab \in G$ :

- start at node  $a$  (or equivalently, start at the identity node and follow any path for  $a$ ).
- follow any path corresponding to  $b$ .

## Another group of size 8

The eight symmetries of a square form a group generated by:

- a  $90^\circ$  counterclockwise rotation  $r$ ,
- a horizontal flip  $f$ .

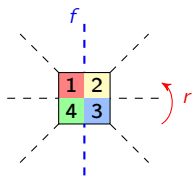

We'll call this group  $\mathbf{Sq} = \langle r, f \rangle$ .

**Question:** Do any of these groups have the same structure? (Are they "isomorphic"?)

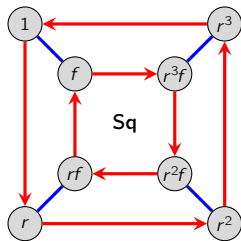
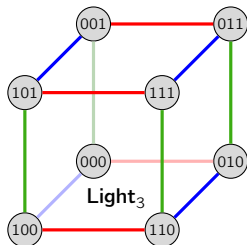
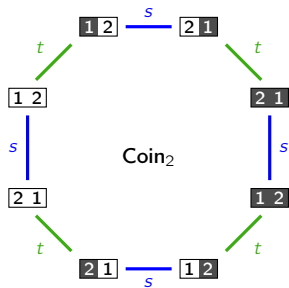

Can you find a property that one group (not graph!) has that the others do not?

## Group presentations

Thus far, we've described a group by its generators.

$G = \langle r, f \rangle$  means " $G$  is generated by  $r$  and  $f$ ."

However, this doesn't tell us how they generate.

### Definition

A **group presentation** for  $G$  is a description of the group as

$$G = \langle \text{generators} \mid \text{relations} \rangle.$$

The vertical bar can be thought of as meaning "subject to".

Even for a fixed set of generators, a group presentation is not unique.

### Key idea

A presentation is just an algebraic way to encode a Cayley graph.

But, it doesn't necessarily tell us *which* Cayley graph!



# Group presentations

Here are some example of presentations:

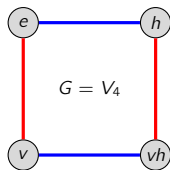

$G = V_4$

$$\langle v, h \mid v^2 = h^2 = e, vh = hv \rangle$$

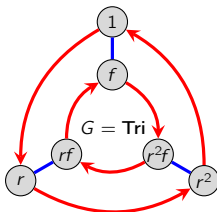

$G = \text{Tri}$

$$\langle r, f \mid r^3 = f^2 = 1, rf = fr^2 \rangle$$

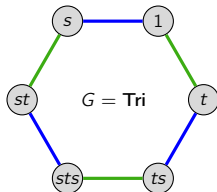

$G = \text{Tri}$

$$\langle s, t \mid s^2 = t^2 = 1, sts = tst \rangle$$

The relation  $r^3 = 1$  is redundant in the second presentation:

$$\begin{aligned} rf = fr^2 &\Rightarrow f(rf) = r^2 \Rightarrow (frf)^2 = r^4 \Rightarrow fr^2f = r^4 \Rightarrow (fr^2)f = r^4 \\ &\Rightarrow (rf)f = r^4 \Rightarrow r = r^4 \Rightarrow 1 = r^3 \end{aligned}$$

But removing  $r^3 = 1$  from  $\text{Tri} = \langle r, f \mid r^3 = f^2 = 1, rf = fr^{-1} \rangle$  yields an infinite group.

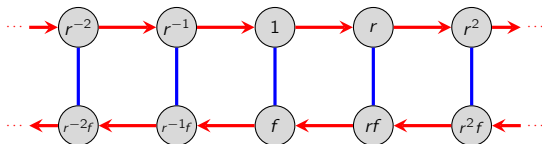

# The free group on 2 generators

$$F_2 = \langle \mathbf{a}, \mathbf{b} \mid \rangle$$

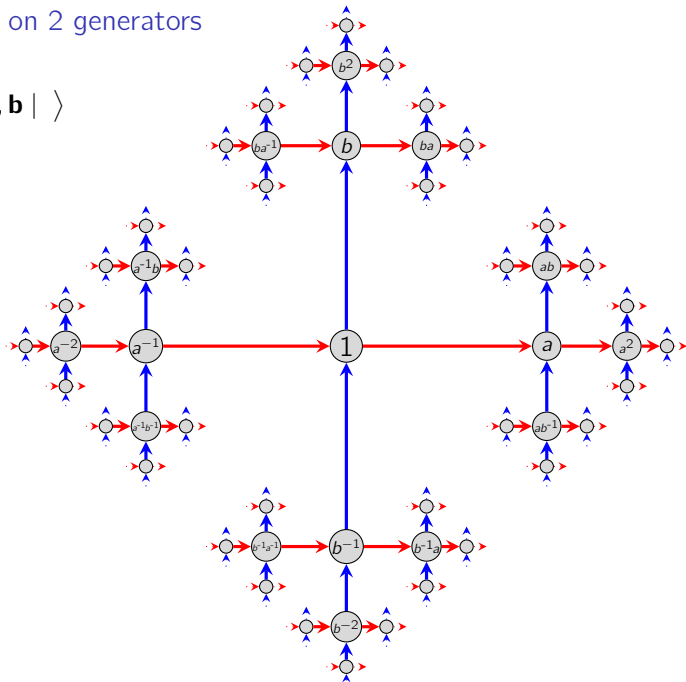

# $D_3$ as a quotient of $F_2$

$$D_3 = \langle r, f \mid r^3 = r^2 = rfrf = 1 \rangle$$

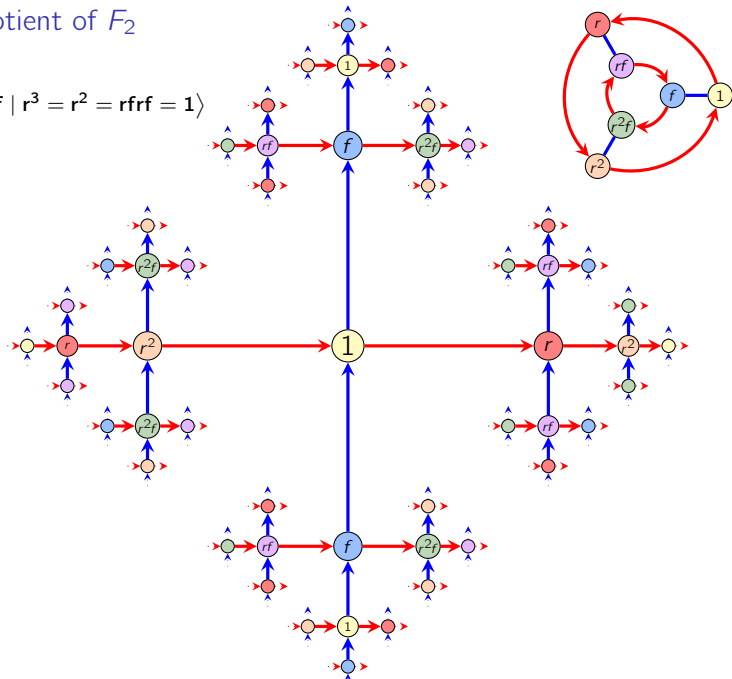

# Group presentations

## The word problem

Given a presentation  $G = \langle g_1, \dots, g_n \mid r_1 = e, \dots, r_m = e \rangle$ , is  $G = \{e\}$ ?

## Exercise

Show that  $G = \langle a, b \mid ab = b^2a, ba = a^2b \rangle$  is the trivial group.

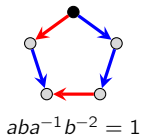

and

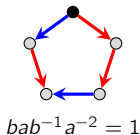

$\implies$



$$G = \langle a, b, \mid a = b = 1 \rangle = \langle 1 \rangle$$

An even harder problem is the **isomorphism problem**: Given  $G_1$  and  $G_2$ , is  $G_1 \cong G_2$ ?

## Question

Given a group presentation that "looks like" a large group, *how can we be absolutely sure?*

# Unsolvability of the word problem

## Theorem

The word problem is **unsolvable**, even for finitely presented groups.

## 4-dimensional sphere problem

Given a 4-dimensional surface, determine whether it is **homeomorphic** to the 4-sphere.

Every surface  $S$  has a group  $\pi_1(S)$  called the **fundamental group** of all “looped paths.”

Four dimensions is big enough that for *any*  $G$ , we can build a surface for which  $\pi_1(S) \cong G$ .

## Theorem

The 4-dimensional sphere problem is unsolvable.

## Summary of the proof

Suppose there exists a solution, and let  $G$  be a group.

1. Build a surface  $S$  such that  $\pi_1(S) \cong G$ .
2. Determine whether  $S$  is a 4-sphere (all loops on a sphere are trivial).
3. This solves the **word problem** for  $G$ . (Contradiction)

## Frieze groups

In architecture, a **frieze** is a long narrow section of a building, often decorated with art.

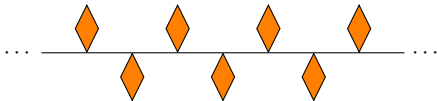

**Figure:** A frieze on the Admiralty, in Saint Petersburg.

They were common on ancient Greek, Roman, and Persian buildings.

Sometimes, but not always, such a pattern repeats.

In mathematics, a **frieze** is a 2-dimensional pattern that repeats in one direction, with a **minimal nonzero translational symmetry**.



### Definition

The symmetry group of a frieze is called a **frieze group**.

**Goal.** *Understand and classify the frieze groups.*

# Frieze groups

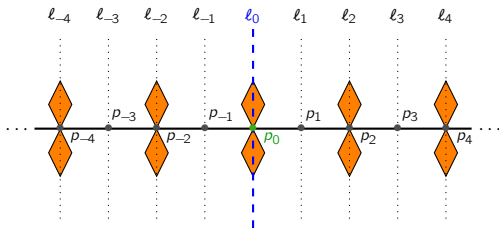

## Definition

Let  $v$  be the unique **vertical reflection**. Symmetries come in infinite families. Define

- $t$ : minimal **translation** to the right
- $h_i$ : **horizontal reflection** across  $l_i$
- $g_i := t^i v = v t^i$ : **glide-reflection**
- $r_i$ : **180° rotation** around  $p_i$

The symmetry group of this frieze consists of the following symmetries:

$$\text{Frz}_1 := \{h_i \mid i \in \mathbb{Z}\} \cup \{r_i \mid i \in \mathbb{Z}\} \cup \{t^i \mid i \in \mathbb{Z}\} \cup \{g_i \mid i \in \mathbb{Z}\}.$$

Note that  $v = g_0$ . Letting  $h := h_0$ ,  $r := r_0$ , and  $g := g_1$ , this frieze group is generated by

$$\text{Frz}_1 := \langle t, h, v \rangle = \langle t, h, r \rangle = \langle t, v, r \rangle = \langle g, h, v \rangle = \dots$$

# Frieze groups

Let's look at how the various reflections and rotations are related:

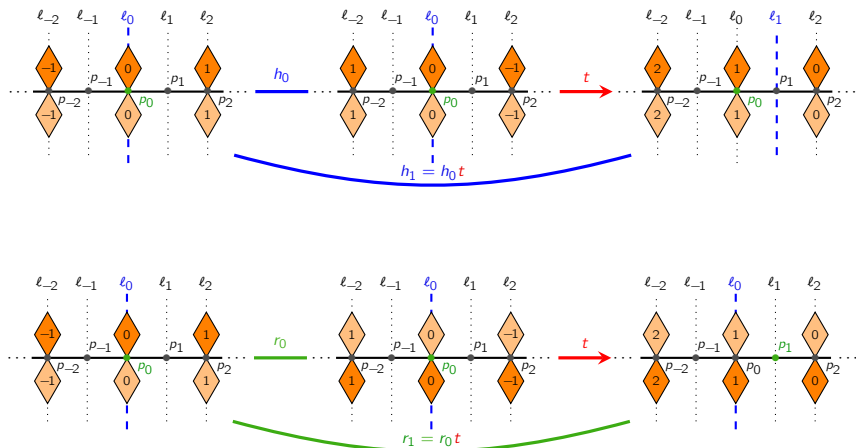

Similarly, it follows that  $h_i t = h_{i+1}$  and  $r_i t = r_{i+1}$  for any  $i \in \mathbb{Z}$ .



## A "smaller" frieze group

Let's eliminate the **vertical symmetry** from the previous frieze group.

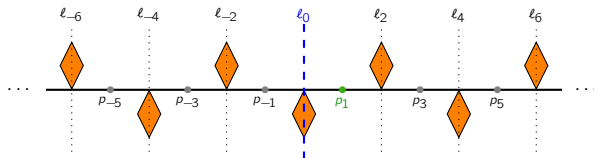

We lose half of the **horizontal reflections** and **rotations** in the process. The frieze group is

$$\text{Frz}_2 := \{g^i \mid i \in \mathbb{Z}\} \cup \{h_{2j} \mid j \in \mathbb{Z}\} \cup \{r_{2k+1} \mid k \in \mathbb{Z}\} = \langle g, h \rangle = \langle g, r \rangle,$$

where  $h = h_0$ ,  $r = r_1$ ,  $g = g_1 = tv$ .

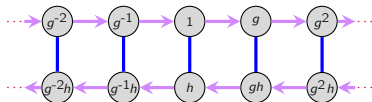
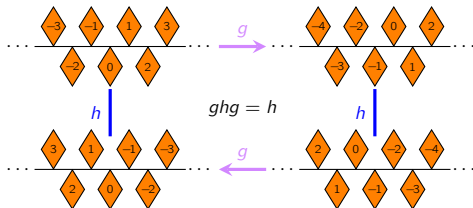

$$\text{Frz}_2 = \langle g, h \mid h^2 = 1, ghg = h \rangle$$

## Other friezes generated by two symmetries

**Frieze 3:** eliminate the vertical flip and all rotations



$$\text{Frz}_3 = \{t^i \mid i \in \mathbb{Z}\} \cup \{h_j \mid j \in \mathbb{Z}\} = \langle t, h \mid h^2 = 1, tht = h \rangle$$

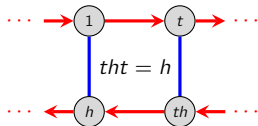

**Frieze 4:** eliminate the vertical flip and all horizontal flips



$$\text{Frz}_4 = \{t^i \mid i \in \mathbb{Z}\} \cup \{r_j \mid j \in \mathbb{Z}\} = \langle t, r \mid r^2 = 1, trt = r \rangle$$

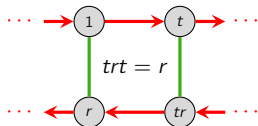

**Frieze 5:** eliminate all horizontal flips and rotations



$$\text{Frz}_5 = \{t^i \mid i \in \mathbb{Z}\} \cup \{g_j \mid j \in \mathbb{Z}\} = \langle t, v \mid v^2 = 1, tv = vt \rangle$$

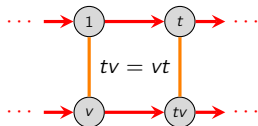

## A Cayley graph of our first frieze group

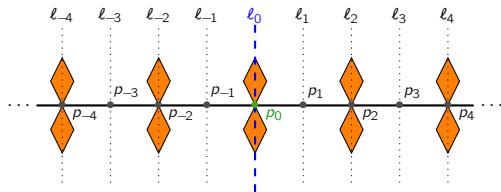

A presentation for this frieze group is

$$\text{Frz}_1 = \langle t, h, v \mid h^2 = v^2 = 1, hv = vh, tv = vt, tht = h \rangle.$$

We can make a Cayley graph by piecing together the “tiles” on the previous slide:

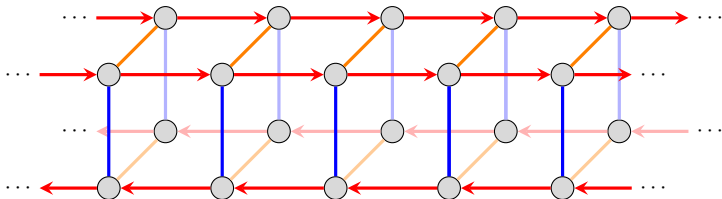

## Classification of frieze groups

Since frieze groups are infinite, each one must contain a translation.

Frieze 6

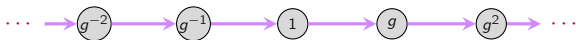
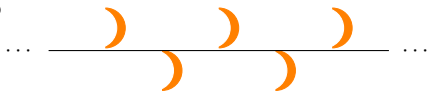

Frieze 7



The frieze groups are  $\mathbf{Frz}_6 = \langle g \mid \quad \rangle \cong \mathbf{Frz}_7 = \langle t \mid \quad \rangle$ .

### Theorem

There are 7 different frieze groups, but only 4 up to isomorphism.

## Wallpaper and crystal groups

A frieze is a pattern that repeats in one dimension.

A next natural step is to look at **discrete patterns** that repeat in higher dimensions.

- a 2-dimensional repeating pattern is a **wallpaper**.
- a 3-dimensional repeating pattern is a **crystal**. The branch of mathematical chemistry that studies crystals is called **crystallography**.

In two dimensions, patterns can have 2-fold, 3-fold, 4-fold, or 6-fold symmetry.

Patterns can also have reflective symmetry, or be “**chiral**.”

Symmetry groups of wallpapers are called **wallpaper groups**.

These were classified by Russian mathematician and crystallographer Evgraf Fedorov (1853–1919).

### Theorem (1877)

There are 17 different wallpaper groups.

Mathematicians like to say “*there are only 17 different types of wallpapers.*”

# The 17 types of wallpaper patterns

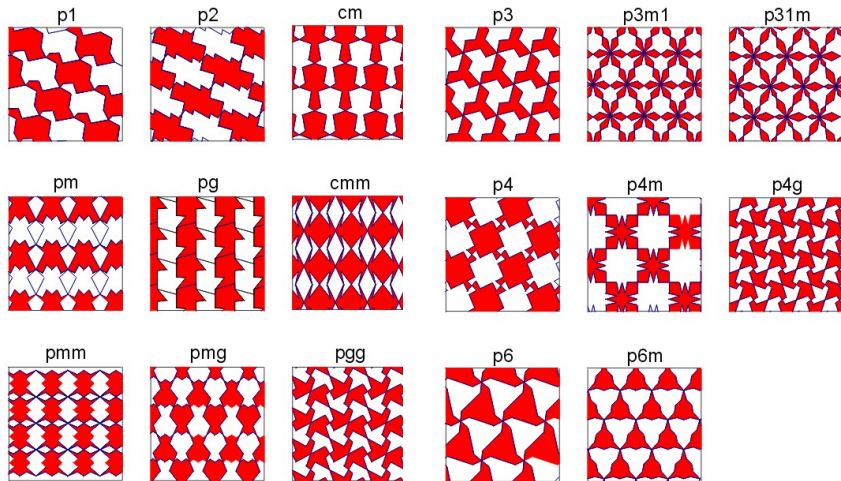

Images by Patrick Morandi (New Mexico State University).

# The 17 types of wallpaper patterns

Here is another picture of all 17 wallpapers, with the official **IUC notation** for the symmetry group, adopted by the International Union of Crystallography in 1952.

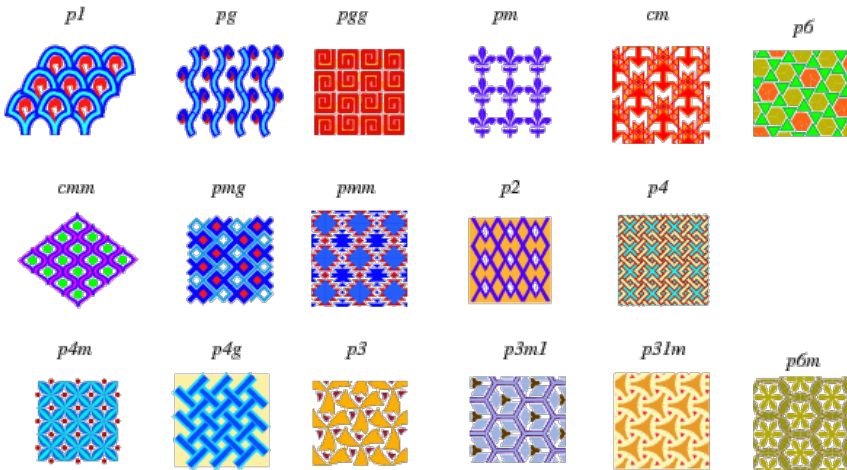

# Symmetry groups of crystals

Symmetry groups of crystals are called **space**, **crystallographic**, or **Fedorv groups**.

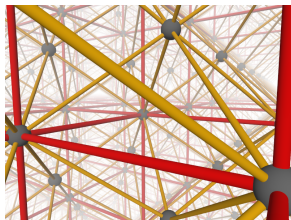
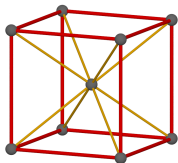

They were classified by Fedorov and Schöflies in 1892.

## Theorem (1877)

There are 230 space groups.

In 1978, a group of mathematicians showed there were exactly 4895 four-dimensional symmetry groups.

In 2002, it was discovered that two were actually the same, so there's only 4894.



## Cayley tables

In some sense, a Cayley graph is a type of “group calculator.”

Another useful tool is something we all learned about in grade school.

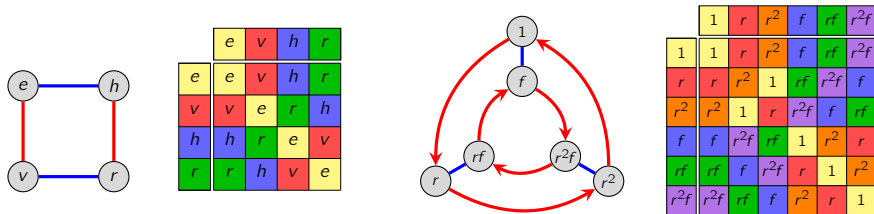

We will call this a **Cayley table**.

### Notational convention

Since  $ab \neq ba$  in general, we will say that the entry in row  $a$  and column  $b$  is  $ab$ .

Cayley tables can reveal patterns that are otherwise hidden.

Sometimes, these patterns only appear if we arrange elements in a certain order.

# The quaternion group

Here are four Cayley graphs of a new group called the **quaternion group**,  $Q_8$ .

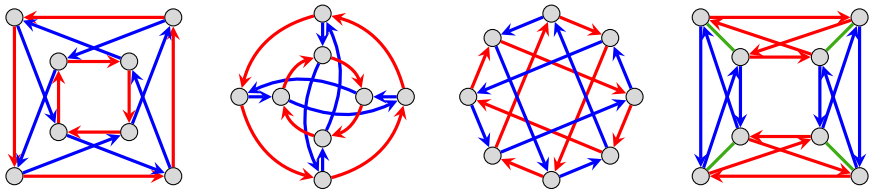

It's in no way clear that these even represent isomorphic groups.

Notice how each one highlights different structural properties.

The first two Cayley graphs emphasize similarities and differences between  $Q_8$  and  $S_4$ .

The group  $Q_8$  is generated by "imaginary numbers"  $i, j, k$ , with  $i^2 = j^2 = k^2 = -1$ .

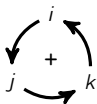

*multiplying in this direction  
yields a positive result*



*multiplying in this direction  
yields a negative result*

## The quaternion group

Two possible presentations for the quaternions are

$$Q_8 = \langle i, j, k \mid i^2 = j^2 = k^2 = ijk = -1 \rangle = \langle i, j \mid i^4 = j^4 = 1, iji = j \rangle.$$

This is one case where it's convenient to *not* use a minimal generating set.

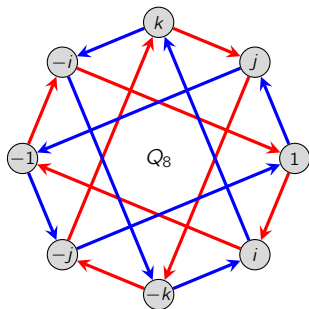

|    |    |    |    |    |    |    |    |    |
|----|----|----|----|----|----|----|----|----|
|    | 1  | i  | j  | k  | -1 | -i | -j | -k |
| 1  | 1  | i  | j  | k  | -1 | -i | -j | -k |
| i  | i  | -1 | k  | -j | -i | 1  | -k | j  |
| j  | j  | -k | -1 | i  | -j | k  | 1  | -i |
| k  | k  | j  | -i | -1 | -k | -j | i  | 1  |
| -1 | -1 | -i | -j | -k | 1  | i  | j  | k  |
| -i | -i | 1  | -k | j  | i  | -1 | k  | -j |
| -j | -j | k  | 1  | -i | j  | -k | -1 | i  |
| -k | -k | -j | i  | 1  | k  | j  | -i | -1 |

Remember how we said that some patterns in Cayley tables only appear if we arrange elements in a certain order?

## The quaternion group

Rather than order elements as  $1, i, j, k, -1, -i, -j, -k$  in

$$Q_8 = \langle i, j, k \mid i^2 = j^2 = k^2 = ijk = -1 \rangle = \langle i, j \mid i^4 = j^4 = 1, iji = j \rangle,$$

let's construct a Cayley table with them ordered  $1, -1, i, -i, j, -j, k, -k$ .

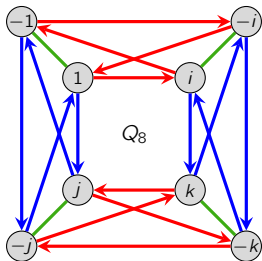

|    | 1  | -1 | i  | -i | j  | -j | k  | -k |
|----|----|----|----|----|----|----|----|----|
| 1  | 1  | -1 | i  | -i | j  | -j | k  | -k |
| -1 | -1 | 1  | -i | i  | -j | j  | -k | k  |
| i  | i  | -i | -1 | 1  | k  | -k | -j | j  |
| -i | -i | i  | i  | -1 | -k | k  | j  | -j |
| j  | j  | -j | -k | k  | -1 | 1  | i  | -i |
| -j | -j | j  | k  | -k | 1  | -1 | -i | i  |
| k  | k  | -k | j  | -j | -i | i  | -1 | 1  |
| -k | -k | k  | -j | j  | i  | -i | 1  | -1 |

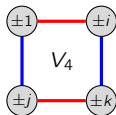

|    | ±1 | ±i | ±j | ±k |
|----|----|----|----|----|
| ±1 | ±1 | ±i | ±j | ±k |
| ±i | ±i | ±1 | ±k | ±j |
| ±j | ±j | ±k | ±1 | ±i |
| ±k | ±k | ±j | ±i | ±1 |

### Remark

“Collapsing” the group  $Q_8 = \{ \pm 1, \pm i, \pm j, \pm k \}$  in this manner reveals the structure of  $V_4$ !

This is an example of taking a **quotient** of a group by a subgroup. We'll return to this!

# Another example of a quotient: $\text{Light}_3$

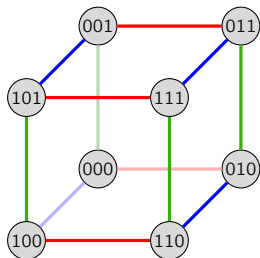

|     |     |     |     |     |     |     |     |     |
|-----|-----|-----|-----|-----|-----|-----|-----|-----|
|     | 000 | 100 | 010 | 110 | 001 | 101 | 011 | 111 |
| 000 | 000 | 100 | 010 | 110 | 001 | 101 | 011 | 111 |
| 100 | 100 | 000 | 110 | 010 | 101 | 001 | 111 | 011 |
| 010 | 010 | 110 | 000 | 100 | 011 | 111 | 001 | 101 |
| 110 | 110 | 010 | 100 | 000 | 111 | 011 | 101 | 001 |
| 001 | 001 | 101 | 011 | 111 | 000 | 100 | 010 | 110 |
| 101 | 101 | 001 | 111 | 011 | 100 | 000 | 110 | 010 |
| 011 | 011 | 111 | 001 | 101 | 010 | 110 | 000 | 100 |
| 111 | 111 | 011 | 101 | 001 | 110 | 010 | 100 | 000 |

"subgroup of  $\text{Light}_3$

|     |     |     |     |     |
|-----|-----|-----|-----|-----|
|     | 000 | 100 | 010 | 110 |
| 000 | 000 | 100 | 010 | 110 |
| 100 | 100 | 000 | 110 | 010 |
| 010 | 010 | 110 | 000 | 100 |
| 110 | 111 | 010 | 100 | 000 |

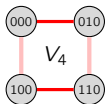

"quotients of  $\text{Light}_3$

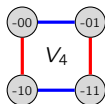

|     |     |     |     |     |
|-----|-----|-----|-----|-----|
|     | -00 | -10 | -01 | -11 |
| -00 | -00 | -10 | -01 | -11 |
| -10 | -10 | -00 | -11 | -01 |
| -01 | -01 | -11 | -00 | -10 |
| -11 | -11 | -01 | -10 | -00 |



|     |     |     |
|-----|-----|-----|
|     | --0 | --1 |
| --0 | --0 | --1 |
| --1 | --1 | --0 |

# Cayley tables

## Proposition

An element cannot appear twice in the same **row** or **column** of a multiplication table.

## Proof

Suppose that in **row**  $a$ , the element  $g$  appears in columns  $b$  and  $c$ . Algebraically, this means

$$ab = g = ac.$$

Multiplying everything on the **left** by  $a^{-1}$  yields

$$a^{-1}ab = a^{-1}g = a^{-1}ac \quad \implies \quad b = c.$$

Thus,  $g$  (or any element) element cannot appear twice in the same **row**.

Verifying that  $g$  cannot appear twice in the same **column** is analogous. (Exercise) □

**Question.** *If we have a table where every element appears in every row and column once, is it a Cayley table for some group?*

## Latin squares and forbidden Cayley tables

A table where every element appears in every row and column once is called a **Latin square**.

Here is an example of two Latin square on a set of five elements, with identity element  $e$ .

|     |     |     |     |     |     |
|-----|-----|-----|-----|-----|-----|
|     | $e$ | $a$ | $b$ | $c$ | $d$ |
| $e$ | $e$ | $a$ | $b$ | $c$ | $d$ |
| $a$ | $a$ | $c$ | $d$ | $b$ | $e$ |
| $b$ | $b$ | $d$ | $a$ | $e$ | $c$ |
| $c$ | $c$ | $b$ | $e$ | $d$ | $a$ |
| $d$ | $d$ | $e$ | $c$ | $a$ | $b$ |

|     |     |     |     |     |     |
|-----|-----|-----|-----|-----|-----|
|     | $e$ | $a$ | $b$ | $c$ | $d$ |
| $e$ | $e$ | $a$ | $b$ | $c$ | $d$ |
| $a$ | $a$ | $e$ | $c$ | $d$ | $b$ |
| $b$ | $b$ | $d$ | $e$ | $a$ | $c$ |
| $c$ | $c$ | $b$ | $d$ | $e$ | $a$ |
| $d$ | $d$ | $c$ | $a$ | $b$ | $e$ |

### Exploratory exercise

Can you construct a Cayley graph for either of these Latin squares? If not, what goes wrong?

## Forbidden Cayley graphs

Motivated by symmetries, we began by calling members of a group “actions”

Then we encountered  $Q_8$ , and it wasn't clear that there even is an underlying action.

It is natural to ask: *Can we use a Cayley graph to define an abstract group?*

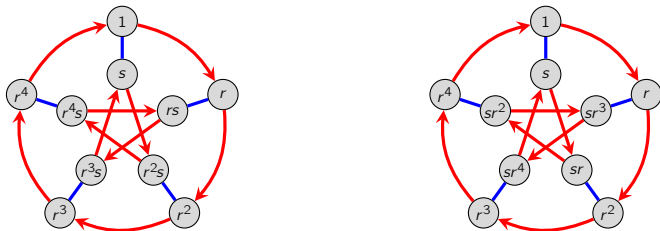

Consider  $r^2s = sr$ , and the blue-red path. This takes 10 iterations from any node to return.

But that would imply that  $G = \langle sr \rangle$ , and every cyclic group must be abelian. (*Why?*)

As before, we can try to write a presentation from this graph:

$$G = \langle r, s \mid r^5 = s^2 = 1, rs = sr^3, r^2s = sr, r^3s = sr^4, r^4s = sr^2 \rangle$$

**Question.** *What group is this?*



## Binary operations and associativity

The last few slides are a cautionary tale for why we need a formal definition.

A group is a **set of elements** satisfying a few properties.

Combining elements can be done with a **binary operation**, e.g.,  $+$ ,  $-$ ,  $\cdot$ , and  $\div$ .

### Definition

If  $*$  is a **binary operation** on a set  $S$ , then  $s * t \in S$  for all  $s, t \in S$ . In this case, we say that  $S$  is **closed** under the operation  $*$ .

Alternatively, we say that  $*$  is a **binary operation on  $S$** .

### Definition

A binary operation  $*$  on  $S$  is **associative** if

$$a * (b * c) = (a * b) * c, \quad \text{for all } a, b, c \in S.$$

Associative basically means *parentheses are permitted anywhere, but required nowhere*.

For example, addition and multiplication are associative, but subtraction is not:

$$4 - (1 - 2) \neq (4 - 1) - 2.$$

# The formal definition of a group

We are now ready to formally define a group.

## Definition

A **group** is a set  $G$  satisfying the following properties:

1. There is an **associative binary operation**  $*$  on  $G$ .
2. There is an **identity** element  $e \in G$ . That is,  $e * g = g = g * e$  for all  $g \in G$ .
3. Every element  $g \in G$  has an **inverse**,  $g^{-1}$ , satisfying  $g * g^{-1} = e = g^{-1} * g$ .

## Remarks

- Depending on context, the binary operation may be denoted by  $*$ ,  $\cdot$ ,  $+$ , or  $\circ$ .
- We frequently omit the symbol and write, e.g.,  $xy$  for  $x * y$ .
- We only use  $+$  if  $G$  is abelian. Thus,  $g + h = h + g$  (always), but in general,  $gh \neq hg$ .
- Uniqueness of the identity and inverses is *not* built into this definition. However, it's an easy exercise to establish.

## A few simple properties

Let's verify uniqueness of the identity and inverses.

### Theorem

Every element of a group has a **unique inverse**.

### Verification

Let  $g$  be an element of a group  $G$ . By definition, it has at least one inverse.

Suppose that  $h$  and  $k$  are both inverses of  $g$ . This means that  $gh = hg = e$  and  $gk = kg = e$ . It suffices to show that  $h = k$ . Indeed,

$$h = he = h(gk) = (hg)k = ek = k,$$

which is what we needed to show. □

The following is relegated to the homework; the technique is similar.

### Theorem

Every group has a **unique identity element**.

## Revisiting our Latin squares

|   |   |   |   |   |   |
|---|---|---|---|---|---|
|   | e | a | b | c | d |
| e | e | a | b | c | d |
| a | a | c | d | b | e |
| b | b | d | a | e | c |
| c | c | b | e | d | a |
| d | d | e | c | a | b |

|   |   |   |   |   |   |
|---|---|---|---|---|---|
|   | e | a | b | c | d |
| e | e | a | b | c | d |
| a | a | e | c | d | b |
| b | b | d | e | a | c |
| c | c | b | d | e | a |
| d | d | c | a | b | e |

The table left describes a group  $\mathbb{Z}_5 := \{0, 1, 2, 3, 4\}$  under addition modulo 5:

$$e = 0, \quad a = 1, \quad b = 3, \quad c = 2, \quad d = 4.$$

The table on the right fails associativity:

$$(a * b) * d = c * d = a, \quad a * (b * d) = a * c = d.$$

Due to [F.W. Light's associativity test](#), there is no shortcut for determining whether the binary operation in a Latin square is associative.

Specifically, the worst-case running time is  $O(n^3)$ , the number of  $(a, b, c)$ -triples.